

Low Frequency Timing Reference Fiber Optic Link

- **Suitable for a range of Timing / Synchronisation and SatCom applications**
- **Suitable for TEMPEST / INFOSEC, EMC, EMP and Secure Data Centre installations**
- **Superior Linear Performance and Low Noise**
- **Transmits all analogue RF timing reference signal formats**
- **Wide range of gain options**
- **Options available to provide LNA and antenna power feeds**
- **Transmission distances of >50km**
- **Compatible with ViaLite range of IP rated outdoor enclosures**
- **SNMP interface for remote monitoring, system programming and control**

Timing and Synchronisation Applications

Many types of operating systems and networks need to maintain accurate synchronisation and the **ViaLiteHD** Timing Reference Fiber Optic Link provides a low cost method that enables RF timing distribution. The wide bandwidth of 10kHz-50MHz allows transmission of various timing reference standards such as MSF, DCF, HBG-75kHz, Loran and eLoran in addition to other common timing signals at 1MHz, 10MHz and 50MHz. The **ViaLiteHD** range of fiber optic links is ideal for long range RF transmission and for use in secure government and military networks.



Timing Reference for SatCom

The **ViaLiteHD** range of fiber optic links connect antennas with control rooms, network operation centres or broadcast headends. In most SatCom installations a reference signal is required to lock oscillators in both up and down converters, the LNB and BUC or transceiver. It is not always possible to achieve this with internally generated signals in each piece of equipment. The **ViaLiteHD** Timing Reference fiber optic link is designed to be used when a central timing reference signal is required to be distributed to remote locations in a SatCom installation using new or existing single mode fiber network.



The **ViaLiteHD** system comprises 13 rack mounted cards that plug into 19" 3U chassis/power supply. Alternatively up to 3 modules can be fitted into a 1U high 19" chassis, or standalone modules are available. A wide range of additional modules and accessories that might be required in any typical installation are also available in the **ViaLiteHD** range.

Also available in the **ViaLiteHD** range is the small form factor OEM module that allows System Integrators and Original Equipment Manufacturers an easy route to build timing reference RF/optical interfaces into their own design.

RF Performance Characteristics

	Rack or OEM Module High Input Level Link	Rack or OEM Module Low Input Level Link	Rack or OEM Module Optical Splitting Link	Rack or OEM Module High Gain
Frequency Range	10kHz - 50MHz	10kHz - 50MHz	10kHz - 50MHz	10kHz - 50MHz
RF Link Gain (nominal)	0 dB ^a (-25dB Tx and +25dB Rx)	0 dB ^a (-5dB Tx and +5dB Rx)	6 dB ^a (-25dB Tx and +31dB Rx)	26 dB ^a (-5dB Tx and +31dB Rx)
Flatness	±0.5dB (max) ^a	±0.5dB (max) ^a	±0.5dB (max) ^a	±0.5dB (max) ^a
Gain Stability	±0.25dB ¹ over operating temperature range @24hrs	±0.25dB ¹ over operating temperature range @24hrs	±0.25dB ¹ over operating temperature range @24hrs	±0.25dB ¹ over operating temperature range @24hrs
VSWR (50 Ohm)	≤1 : 1.5 ¹	≤1 : 1.5 ¹	≤1 : 1.5 ¹	≤1 : 1.5 ¹
CNR	60dB ^{1 b}	62dB ^{1 b}	60dB ^{1 b}	62dB ^{1 b}
Nominal Input Signal	0dBm	-20dBm	0dBm	-20dBm
Nominal Output Signal	0dBm	-20dBm	0dBm	-20dBm
Noise Figure	37dB ^{1 a}	15dB ^{1 a}	37dB ^{1 a}	15dB ^{1 a}
Input P1dB	+13dBm ^{1 c}	-8dBm ^{1 c}	+13dBm ^{1 c}	-8dBm ^{1 c}
Maximum Input Power (without damage)	+25dBm ¹	+13dBm ¹	+25dBm ¹	+13dBm ¹
Output IP3	+15dBm ^{1 c}	-5dBm ^{1 c}	+21dBm ^{1 c}	+20dBm ^{1 c}
SFDR	108dB Hz 2/3 ^{1 b}	108dB Hz 2/3 ^{1 b}	105dB Hz 2/3 ^{1 b}	105dB Hz 2/3 ^{1 b}
External LNA Voltage	Capability for +5V or +12V feed from RF input of Tx	Capability for +5V or +12V feed from RF input of Tx	Capability for +5V or +12V feed from RF input of Tx	Capability for +5V or +12V feed from RF input of Tx
^a nominal input power @ 0dB optical loss ^b nominal input power @ 1dB optical loss ^c nominal input power @ 5dB optical loss ^d 2.4kHz bandwidth ¹ typical				

Optical Performance Characteristics

	Rack or OEM Module High Input Level Link	Rack or OEM Module Low Input Level Link	Rack or OEM Module Optical Splitting Link Low Gain	Rack or OEM Module Optical Splitting Link High Gain
Laser Type	DFB	DFB	DFB	DFB
Optical Wavelength	1310 nm ± 20 nm (1550nm/CWDM options)	1310 nm ± 20 nm (1550nm/CWDM options)	1310 nm ± 20 nm (1550nm/CWDM options)	1310 nm ± 20 nm (1550nm/CWDM options)
Optical Power Output	4.5 dBm (nominal) (3mW)	4.5 dBm (nominal) (3mW)	4.5 dBm (nominal) (3mW)	4.5 dBm (nominal) (3mW)
Optical Connector	SC/APC (E2000/APC and FC/APC options)	SC/APC (E2000/APC and FC/APC options)	SC/APC (E2000/APC and FC/APC options)	SC/APC (E2000/APC and FC/APC options)

Part Numbers and Options

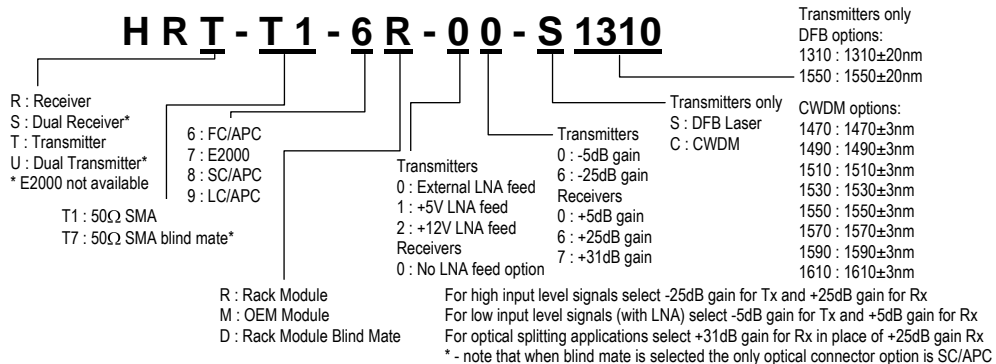

Mechanical Dimensions

