



1:1 ELECTROMECHANICAL REDUNDANCY SWITCH MODULE

PPM's **ViaLite** Electromechanical Redundancy Switch module allows users to implement 1:1 redundancy switching with ViaLite RF modules.

The Electromechanical Redundancy Switch module contains a broadband RF switch that provides very low insertion loss and very high levels of isolation. It may be controlled automatically by other ViaLite RF modules. Alternatively, it may be controlled directly by the user's equipment.

The primary, secondary and Redundancy Switch modules can be fitted into any position in the ViaLite 19" Rack Chassis. They can even be fitted into different chassis, therefore permitting the maximum possible flexibility in configuration.

Together with the ViaLite dual redundant power supplies, the 1:1 Electromechanical Redundancy Switch provides the highest possible availability for the ViaLite system.

PPM's **ViaLite** 1:1 Electromechanical Redundancy Switch offers the following key advantages:

- Electromechanical switch for excellent RF performance - low insertion loss and high isolation
- High reliability (>5 million cycles)
- DC to >3GHz operation
- Compact plug-in module

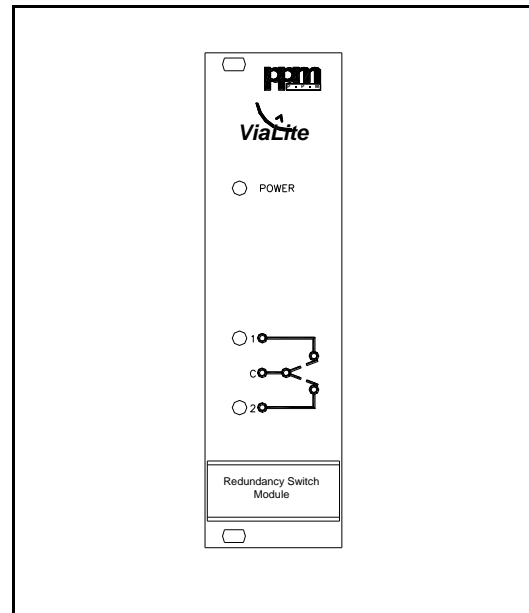

Complementary PPM **ViaLite** Products

- RF Signal modules for RF GPS, L Band, 70/140MHz, Broadband 2kHz-1500MHz and 10MHz-3GHz etc.
- ViaLite Alarm Concentrator
- 19" Rack Case
- Dual redundant power supplies for maximum availability
- Broadband RF Splitter

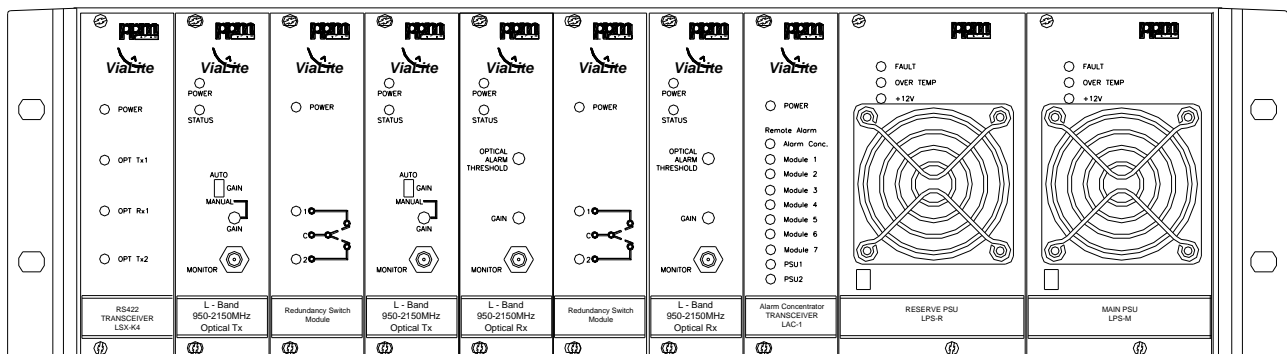

ViaLite ELECTROMECHANICAL REDUNDANCY SWITCH APPLICATION EXAMPLES

In a typical configuration, an RF signal is split and fed to two ViaLite transmit modules. These modules are connected via two separate optical fibers to two ViaLite receiver modules. These form the primary and secondary paths. The RF outputs of the primary and secondary receivers are connected to inputs 1 and 2 respectively of the Redundancy Switch module. The RF output on the Common port is fed to the user equipment. A control cable connected between the Redundancy Switch and the primary receiver ensures that the Redundancy Switch selects the Secondary path in the event of a failure in the primary path.

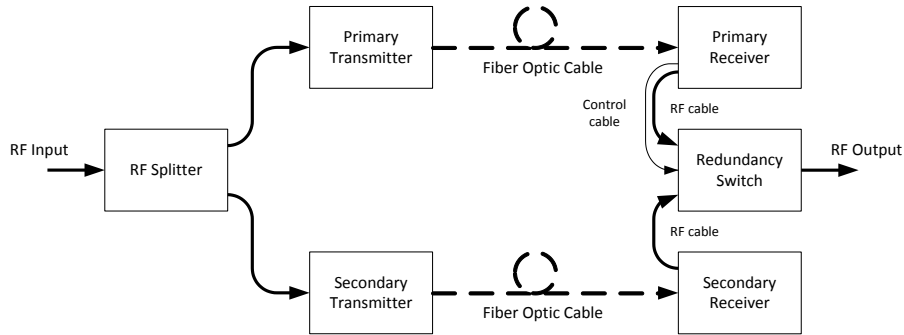

Figure 1: Typical 1:1 redundancy configuration

In an alternative configuration, the paths may be switched at the transmitter end instead of being split. This method has less impact on the Carrier-to-Noise ratio.

The fully switched configuration may be implemented by use of ViaLite Alarm Concentrator and RF Splitter modules. The Alarm Concentrators convey alarm information from the receiver end to the transmitter end, where it may be used to switch the RF signal between the primary and secondary path transmitters in the event of a failure

anywhere between the transmitter and receiver modules.

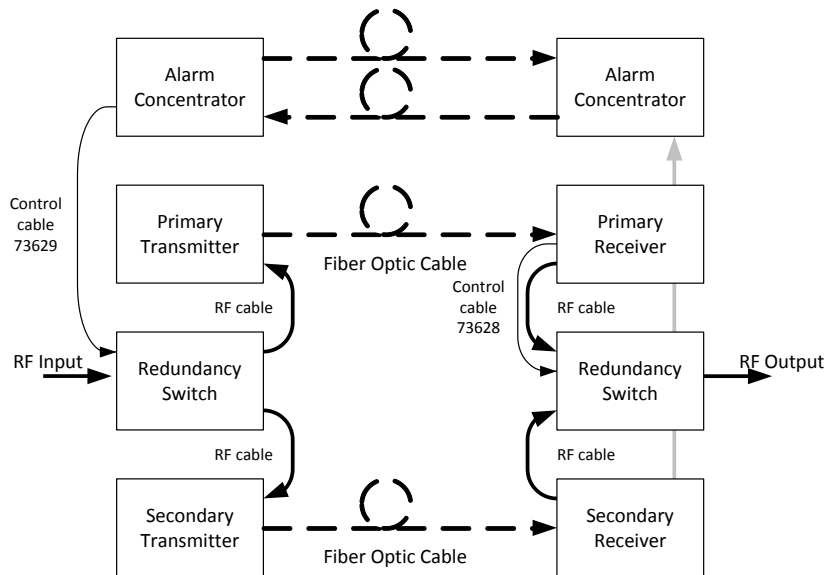

Figure 2: Typical fully switched 1:1 redundancy configuration

The configuration shown in Figure 2 can be expanded with additional receivers, transmitters and redundancy switches to provide a second fully switched dual redundant path in the same chassis.

ViaLite REDUNDANCY SWITCH SPECIFICATIONS

Parameter	LRS-10	LRS-30	LRS-40
Bandwidth	DC-3GHz	DC-200MHz	DC-200MHz
Impedance	50Ω	75Ω	50Ω
Insertion Loss	10 - 200MHz : <0.5dB 950 - 1750MHz : <1.5dB 1750 - 3000MHz : <2.0dB	<0.6dB	<0.6dB
Isolation	DC - 500MHz: >60dB 500MHz - 3GHz: >50dB	>60dB	>60dB
VSWR	DC - 500MHz: <1.3:1 500MHz - 3GHz: <1.8:1	DC - 500MHz: <1.3:1	DC - 500MHz: <1.3:1
Power consumption	1.5W Typ (switched to Main Path) or 3.6W Typ (switched to Redundant Path)		
Operating Conditions			
Operating Temperature	-10°C to +50°C		
Storage Temperature	-40°C to +70°C		
User Interface			
Front panel indicator LEDs	Power - Indicates DC power is applied to the module 1 - Indicates Primary RF path is selected 2 - Indicates Secondary RF path is selected		
Switch control	Via Pin 1 on 15-way D-Type female on 19" Rack Chassis or Converter Sleeve. Leave Pin 1 open to switch RF from Common Port to Port 2. Connect Pin 1 to ground (Pin 8) to switch RF from Common Port to Port 1.		
RF Input/Output	1 - Primary port 2 - Secondary port C - Common port		
RF Connector	SMA 50Ω	BNC 75Ω	BNC 50Ω
Physical Format			
Housing Options	Rack Plug-in Module - suitable for Rack Chassis or Plug-in Converter Sleeve		
Supply Voltage	+12Vdc from LRK power supply		
Rack Plug-in Module	+12Vdc from external supply		
Weight	600g		
Rack plug-in module	600g + module		
Plug-in Converter Sleeve	600g + module		
Rack Mount Case Suitability	LRK1S, LRK2S		

Physical Dimensions

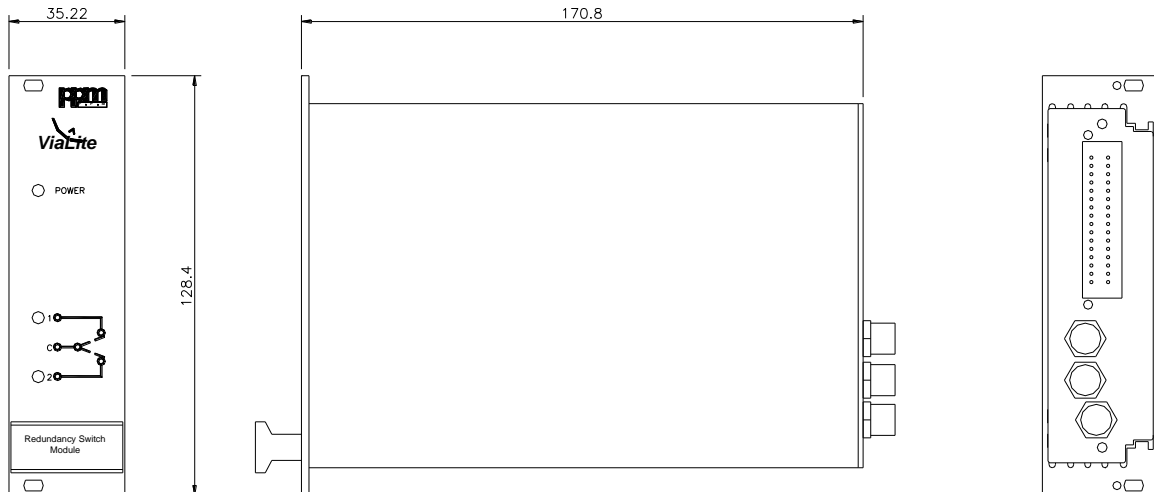

Figure 3: Plug-in Module

Ordering Information

Part Number	RF Connection
LRS-10	50Ω SMA
LRS-30	75Ω BNC
LRS-40	50Ω BNC

19" Rack Case Solutions

Part Number	Description
LRK1S	19" Rack Case 3U for desktop or 19" rack installation. Accommodates up to 8 plug-in modules and 2 mains power supplies.
LRK2S	19" Rack Case 3U for 19" rack installation. Accommodates up to 8 plug-in modules and 2 mains power supplies.
LPS-M	Main Power Supply plug-in for LRK1S or LRK2S.
LPS-R	Reserve Power Supply plug-in for LRK1S or LRK2S.
75004	19" Rack Case, 1U for desktop or 19" rack installation, integral power supply, accommodates 3 plug-in modules.

Accessories

Part Number	Description
LRD-x	Broadband Low-loss RF Splitter, 10-2500MHz. (Substitute 1, 3 or 4 for x to select connector type. -1 for 50Ω SMA; -3 for 75Ω BNC or -4 for 50Ω BNC)
LAC-1	Alarm Concentrator Transceiver Fiber Optic Link module
73628	Control cable connection between Redundancy Switch and the primary module. Length is 0.5m. Required at receiver end for automatic switching.
73629	Control cable connection between Alarm Concentrator and up to seven Redundancy Switches. Lengths
73630	SMA Plug to SMA Plug 50Ω RF cable assembly, 0.5m length. Two required for the RF cable connection between LRS-10 Redundancy Switch and primary and secondary modules.
73662	BNC Plug to BNC Plug 75Ω RF cable assembly, 0.5m length. Two required for the RF cable connection between LRS-30 Redundancy Switch and primary and secondary modules.
73661	BNC Plug to BNC Plug 50Ω RF cable assembly, 0.5m length. Two required for the RF cable connection between LRS-40 Redundancy Switch and primary and secondary modules.

CONTACT US

ViaLite LLC, 5 Stanton Court, Plainsboro, New Jersey 08536, USA
Tel +1 800 374 3078 E-mail sales@vialite-usa.com Web www.vialite-usa.com