

GPS Fiber Optic Link

- **Suitable for a range of Timing / Synchronisation applications**
- **Superior Linear Performance and Low Noise**
- **Transmits all common GPS / GALILEO / GLONASS bands**
- **Wide range of gain options**
- **Standard LNA and antenna power feeds**
- **GPS receiver alarm defeat feature**
- **Transmission distances of >50km**
- **Compatible with ViaLite range of IP rated outdoor enclosures**
- **SNMP Network Control Module Compatible**

GPS Signal Transfer Over Fiber

Many types of operating systems and networks need to maintain accurate synchronisation and the **ViaLite** GPS Link provides a low cost method that enables GPS signal distribution over long distance to inaccessible locations. The bandwidth of GPS Link allows transmission of L1 and L2 GPS bands. The **ViaLite** GPS Fiber Optic Link has been designed with a very low noise figure specifically for GPS signals which are often very low intensity at the GPS antenna. The wide dynamic range of the link results in negligible degradation of satellite signals due to noise or interfering signals. The GPS link is ideal for providing a GPS derived timing signal reference to equipment positioned where no GPS signal is available, for example in tunnels or underground mines.

In a typical installation the **ViaLite** GPS Fiber Optic Link acts as a very low loss extension between the GPS antenna and receiver as shown on the right.

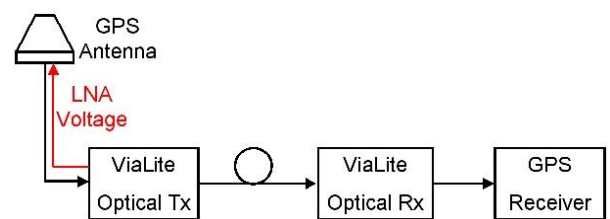

The **ViaLite** system comprises rack mounted modules that plug into 19" 3U chassis/power supply. Alternatively up to 3 modules can be fitted into a 1U high 19" chassis, or standalone modules are available. A wide range of additional modules and accessories that might be required in any typical installation are also available in the **ViaLite** range.

The most recent addition to the **ViaLite** range is the small form factor OEM module that allows System Integrators and Original Equipment Manufacturers an easy route to build timing reference RF/optical interfaces into their own design.



RF Performance Characteristics

	Rack Module	OEM Module
Frequency Range	1150 – 1700 MHz Including GPS L1, L2, L3, L4, L5, Glonass and Galileo frequencies	1150 – 1700 MHz Including GPS L1, L2, L3, L4, L5, Glonass and Galileo frequencies
RF Link Gain (nominal)	0 dB ^a	0 dB ^a
Flatness	±0.3 dB (typical) ^a ±0.75 dB (max) ^a	±0.3 dB (typical) ^a ±0.75 dB (max) ^a
Gain Stability	±0.25 dB ¹ over operating temperature range during 24hrs	±0.25 dB ¹ over operating temperature range during 24hrs
VSWR (50 Ohm)	≤1 : 1.5 ¹	≤1 : 1.5 ¹
CNR	65 dB ^{1 c}	65 dB ^{1 c}
Nominal Input Signal	-30 dBm	-30 dBm
Noise Figure	15 dB ^{1 a}	15 dB ^{1 a}
Input P1dB	-7 dBm ^{1 a}	-7 dBm ^{1 a}
Input IP3	+4 dBm ^{1 a}	+4 dBm ^{1 a}
Maximum Input Power (without damage)	+15 dBm ¹	+15 dBm ¹
SFDR @ 0dB optical loss	110dB Hz 2/3 ^{1 a}	110dB Hz 2/3 ^{1 a}
SFDR @ 1dB optical loss	109dB Hz 2/3 ^{1 b}	109dB Hz 2/3 ^{1 b}
External LNA Voltage	Capability for +5V or +12V@ 80mA feed from RF input of Tx	Capability for external voltage feed to RF input of Tx
^a nominal input power @ 0dB optical loss ^b nominal input power @ 1dB optical loss ^c nominal input signal, 2.046MHz Bandwidth @ 1dB optical loss ¹ typical		

Optical Performance Characteristics

	Rack Module	OEM Module
Laser Type	DFB	DFB
Optical Wavelength	1310 nm ± 20 nm (1550nm/CWDM options)	1310 nm ± 20 nm (1550nm/CWDM options)
Optical Power Output	4.5dBm (nominal) (3mW)	4.5dBm (nominal) (3mW)
Optical Connector	FC/APC (E2000/APC and SC/APC options)	E2000/APC (FC/APC and SC/APC options)
All measurements taken at 25°C unless otherwise stated		

Part Numbers and Options

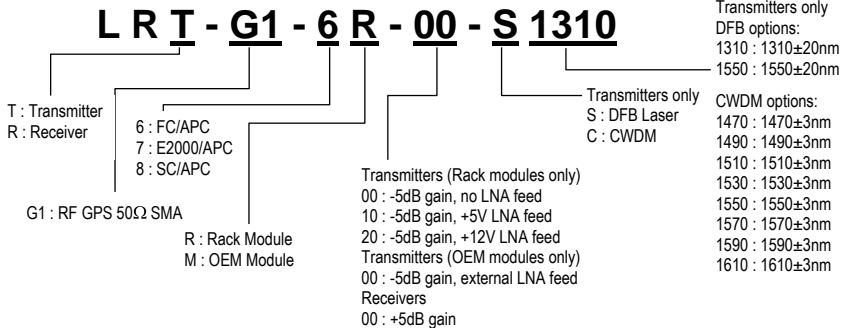

Accessories

LRK2S	3U 8 Module Chassis + 2 PSU's
LPS-M	Main Power Supply Module
LPS-R	Reserve Power Supply Module
75003	Single Module Sleeve
75004	1U 3 Slot Chassis
LRD-x	RF Splitter Module
LRS-xx	1:1 Redundancy Switch
LSX-xx-xx	Ethernet or Serial Digital Module
LRC-1	SNMP Network Control Module
75010-xxx	Outdoor Enclosure

Mechanical Dimensions

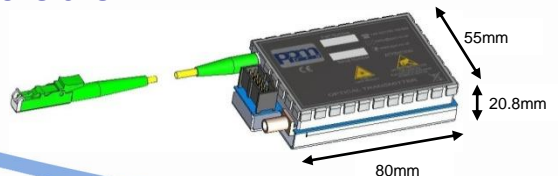

OEM Module

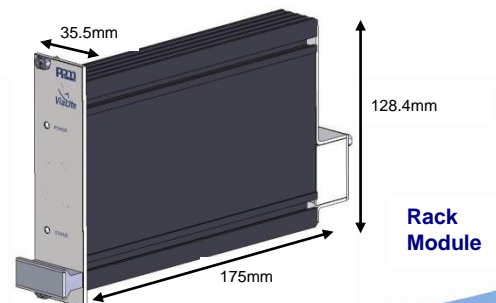

Rack Module