

## ***IF 70/140MHz Fiber Optic Interfacility Links***

- ***Low Noise***
- ***High Spurious Free Dynamic Range***
- ***Protocol Transparent – transmits all video, data and audio modulation formats***
- ***Transmission distances of >50km***
- ***50Ω or 75Ω impedance options***
- ***Interfaces with M&C systems for remote monitoring***
- ***Multiple carrier up or down link transmission***
- ***SNMP Network Control Module Compatible***

### **Advanced Satcom Technology**

The **ViaLite** range of fiber optic links connect antennas with control rooms, network operation centres or broadcast headends.

**ViaLite** links offer more than an alternative to coaxial cabling in teleport earth stations. They have been designed to provide very low carrier-to-noise ratio and extremely linear performance. This means a cost effective technically superior installation for the satcom user. **ViaLite** systems have been engineered to give industry leading performance when compared with any other fiber optic link. Only **ViaLite** links have ultra wide dynamic range so that auto gain control is not required to cope with changing signal intensity caused by meteorological conditions.



A range of options to suit a variety of installations is offered, such as 75Ω or 50Ω impedance with either BNC or SMA connectors. Optical connector options include FC, E2000 and SC.



*The **ViaLite** system comprises rack mounted modules that plug into 19" 3U chassis/power supply. Alternatively up to 3 modules can be fitted into a 1U high 19" chassis, or standalone modules are available. A wide range of additional modules and accessories that might be required in any typical satcom installation are also available in the **ViaLite** range.*

*The most recent addition is the small form factor OEM module that allows System Integrators and Original Equipment Manufacturers an easy route to build RF/optical interfaces into their own design.*



## RF Performance Characteristics

	Rack Module Fixed Gain Link (50Ω)	Rack Module Variable Gain Link (50Ω)	OEM Module Variable Gain Link (50Ω)	Rack Module Variable Gain Link (75Ω)
Frequency Range	10 - 200 MHz	10 - 200 MHz	10 - 200 MHz	10 - 200 MHz
Flatness	± 0.50 dB (max) <sup>a</sup> ± 0.20 dB (typical) <sup>a</sup> ± 0.10 dB in any 36 MHz <sup>a1</sup>	± 0.50 dB (max) <sup>a,d</sup> ± 0.20 dB (typical) <sup>a,d</sup> ± 0.10 dB in any 36 MHz <sup>a1</sup>	± 0.50 dB (max) <sup>a,d</sup> ± 0.20 dB (typical) <sup>a,d</sup> ± 0.10 dB in any 36 MHz <sup>a1</sup>	± 0.75 dB (max) <sup>a,d</sup> ± 0.30 dB (typical) <sup>a,d</sup> ± 0.10 dB in any 36 MHz <sup>a1</sup>
VSWR	1:1.5 <sup>t</sup>	1:1.5 <sup>t</sup>	1:1.5 <sup>t</sup>	1:1.5 <sup>t</sup>
IMD	-58 dB <sup>t,c</sup>	-58 dB <sup>t,c</sup>	-58 dB <sup>t,c</sup>	-57 dB <sup>t,c</sup>
CNR	58 dB <sup>t,b</sup>	58 dB <sup>t,b</sup>	58 dB <sup>t,b</sup>	59 dB <sup>t,b</sup>
Test Input Signal	-20 dBm	-20 dBm	-20 dBm	-20 dBm
Test Output Signal	-20 dBm	-20 dBm	-20 dBm	-20 dBm
Maximum Input Power (without damage)	+15 dBm	+15 dBm	+15 dBm	+15 dBm
Gain Stability	0.25 over 24 hrs	0.25 over 24 hrs	0.25 over 24 hrs	0.25 over 24 hrs
RF Link Gain (nominal)	9 dB <sup>a</sup>	9 ± 3 dB <sup>a,d</sup>	9 ± 3 dB <sup>a,d</sup>	9 ± 3 dB <sup>a,d</sup>
Output IP3	8 dBm <sup>t,c</sup>	8 dBm <sup>t,c</sup>	8 dBm <sup>t,c</sup>	8 dBm <sup>t,c</sup>
Input IP3	10 dBm <sup>t,c</sup>	10 dBm <sup>t,c</sup>	10 dBm <sup>t,c</sup>	10 dBm <sup>t,c</sup>
Input P1dB	-2 dBm <sup>t</sup>	-2 dBm <sup>t</sup>	-2 dBm <sup>t</sup>	-3 dBm <sup>t</sup>
Noise Figure	20 dB <sup>t,a</sup>	20 dB <sup>t,a</sup>	20 dB <sup>t,a</sup>	19 dB <sup>t,a</sup>
SFDR	109 dB Hz 2/3 <sup>t,b</sup>	109 dB Hz 2/3 <sup>t,b</sup>	110 dB Hz 2/3 <sup>t,b</sup>	109 dB Hz 2/3 <sup>t,b</sup>

<sup>a</sup> nominal input power @ 0 dB optical loss    <sup>b</sup> nominal input power @ 1 dB optical loss    <sup>c</sup> nominal output power @ 5 dB optical loss    <sup>d</sup> 0dB variable gain offset    <sup>t</sup> typical

## Optical Performance Characteristics

	Rack Module Fixed Gain Link (50Ω)	Rack Module Variable Gain Link (50Ω)	OEM Module Variable Gain Link (50Ω)	Rack Module Variable Gain Link (75Ω)
Laser Type	DFB	DFB	DFB	DFB
Optical Wavelength	1310 nm ± 20 nm (1550nm/CWDM options)	1310 nm ± 20 nm (1550nm/CWDM options)	1310 nm ± 20 nm (1550nm/CWDM options)	1310 nm ± 20 nm (1550nm/CWDM options)
Optical Power Output	4.5 dBm (nominal)	4.5 dBm (nominal)	4.5 dBm (nominal)	4.5 dBm (nominal)
Optical Connector	FC/APC (E2000/APC and SC/APC options)	FC/APC (E2000/APC and SC/APC options)	FC/APC (E2000/APC and SC/APC options)	FC/APC (E2000/APC and SC/APC options)

## Part Numbers and Options

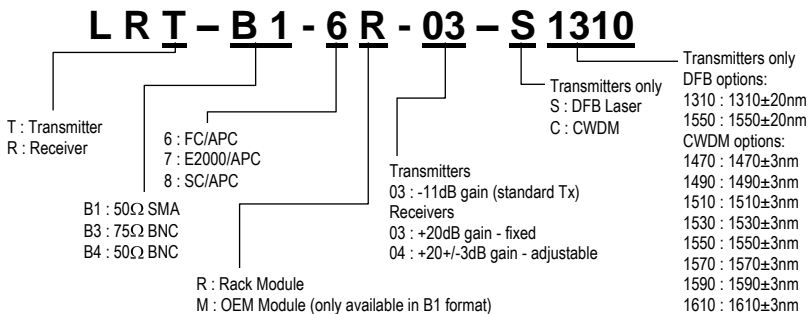

## Accessories

LRK2S	3U 8 Module Chassis + 2 PSU's
LPS-M	Main Power Supply Module
LPS-R	Reserve Power Supply Module
75003	Single Module Sleeve
75004	1U 3 Slot Chassis
LRD-x	RF Splitter Module
LRS-xx	1:1 Redundancy Switch
LSX-xx-xx	Ethernet or RS422 Module
LRC-1	SNMP Network Control Module
75010-xxx	Outdoor Enclosure

## Mechanical Dimensions

