

Wideband Fiber Optic Link

- **2kHz to 4.2GHz bandwidth operation**
- **Suitable for SatCom / WiMax / WiFi / Cellular / TETRA and other applications**
- **Superior Linear Performance and Low Noise**
- **High Spurious Free Dynamic Range – negligible signal loss**
- **Transmits all signal formats**
- **Transmission distances of >50km**
- **Interfaces with M&C systems for remote monitoring**
- **Multiple signal carrier transmission**
- **SNMP Network Control Module Compatible**

Wideband RF-Over-Fiber

The **ViaLite** range of fiber optic links connect antennas with control rooms, network operation centres or broadcast headends. The Wideband Fiber Optic Link is designed to provide a high performance, highly reliable cross site connection between communications equipment in a vast range of different applications.

In Satcom the 2kHz-4.2GHz bandwidth is compatible with all common signals encountered, from low frequency timing codes through L band into the C band receive range.



Other potential applications of the Wideband Link include bi-directional configurations to carry the main RF payload in TETRA, Cellular or WiMAX repeaters and base stations. The bandwidth is also designed for use in secure antenna remoting for special forces or government installations. **ViaLite** RF-over-fiber technology is immune to electrical noise or interference and enables distributed antenna capabilities allowing single transmit to multiple receive points. The technology is independent of modulation format and avoids the need for cascaded amplifier chains, improving reliability.



The **ViaLite** system comprises rack mounted modules that plug into 19" 3U chassis/power supply. Alternatively up to 3 modules can be fitted into a 1U 19" chassis, or standalone modules are available. A wide range of additional modules and accessories that might be required in any typical installation are also available in the **ViaLite** range, including several types of outdoor enclosures.

The most recent addition to the **ViaLite** range is the small form factor OEM module that allows System Integrators and Original Equipment Manufacturers an easy route to build RF/optical interfaces into their own design.



RF Performance Characteristics

	Rack Module Wideband Link	OEM Module Wideband Link
Frequency Range	2 kHz – 4.2 GHz	2 kHz – 4.2 GHz
Link Gain (nominal)	0 dB ^{a b}	0 dB ^{a b}
Flatness (max) ^a	±1 dB (10MHz – 3GHz), ±1.5 dB (3 - 4.2GHz), +2.5/-1.5 dB (2kHz - 10MHz)	±1 dB (10MHz - 3GHz), ±1.5 dB (3 - 4.2GHz), +2.5/-1.5 dB (2kHz - 10MHz)
Gain Stability (max)	±3 dB over operating temperature range	±3 dB over operating temperature range
VSWR (50 Ohm)	<2 : 1 ^t	<2 : 1 ^t
CNR	>107 dB ^{a c d t}	>107 dB ^{a c d t}
Noise Figure	23 dB ^{a c t}	23 dB ^{a c t}
Input P1dB	+3 dBm ^{c t}	+3 dBm ^{c t}
Maximum Input Power (without damage)	+15 dBm	+15 dBm
Output IP3	+13 dBm ^{b c t}	+13 dBm ^{b c t}
Input IP3	+13 dBm ^{c t}	+13 dBm ^{c t}
SFDR	109 dB Hz 2/3 ^{b t}	109 dB Hz 2/3 ^{b t}
External LNA Voltage	Option for the module to come with +5V or +12V feed from RF input of Tx	External LNA feed can be supplied into pin on Tx module which is directed out of centre pin on RF input connector
^a nominal input power (-10 dBm) ^b 0 dB optical loss ^c @ 1.2GHz ^d 2.4kHz bandwidth ^t typical		

Optical Performance Characteristics

	Rack Module Wideband Link	OEM Module Wideband Link
Laser Type	DFB	DFB
Optical Wavelength	1310 nm ± 20 nm (1550nm/CWDM options)	1310 nm ± 20 nm (1550nm/CWDM options)
Optical Power Output	4.5 dBm (nominal) (3mW)	4.5 dBm (nominal) (3mW)
Optical Connector	FC/APC (E2000/APC and SC/APC options)	FC/APC (E2000/APC and SC/APC options)

Part Numbers and Options

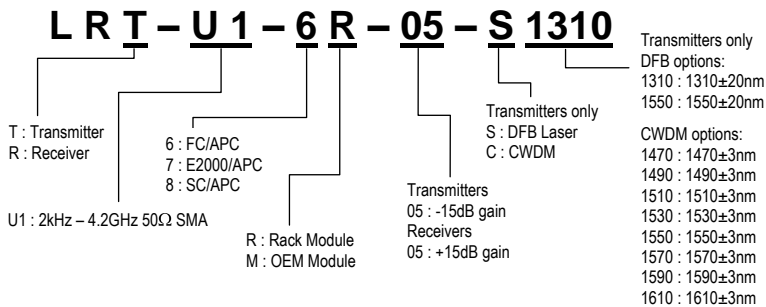

Accessories

LRK2S	3U 8 Module Chassis + 2 PSU's
LPS-M	Main Power Supply Module
LPS-R	Reserve Power Supply Module
75003	Single Module Sleeve
75004	1U 3 Slot Chassis
LRD-x	RF Splitter Module
LRS-xx	1:1 Redundancy Switch
LSX-xx-xx	Ethernet or Serial Digital Module
LRC-1	SNMP Network Control Module
75010-xxx	Outdoor Enclosures

Mechanical Dimensions

